

FastRack 510[™] Installation Manual 5,6 & 10dg



Rev: 210620ER

Introduction

Our mission is to provide innovative Solar PV Racking solutions that are intuitive , durable and cost effective. Our goal is to enable the installation of solar PV on every suitable flat roof/ground mount in the world.

Sollega Simplifies and accelerates the adoption of solar energy technologies by reducing the mounting and installation costs associated with solar arrays. Our FR510 solar mounting system reduces installation time and overall project costs associated with the installation of solar PV.

As the solar industry expands at a quicker rate, speed of deployment is key to meeting demand. We see installation and labor as the logical next steps to reducing the cost of PV. Our one piece injection molded FR510 arrives to the job site ready to install requiring no assembly. Our systems are efficient to ship, stage and install.

Product Profile

Sollega designs, tests and manufactures solar mounting solutions. We injection mold our racking in Baldwin Park California. The FastRack (FR510) is a patented, one-piece, injection molded solar racking system designed for both commercial low-pitch roofs and ballasted ground mount installations. It is injection molded utilizing Glass-filled Nylon for strength and durability (25 year warranty) in a lightweight part (4.6 lbs). It is also designed for simple assembly and disassembly at the end of its useful life and is 100% recyclable.

Sollega FR510 is compatible with most common solar panels currently on the market. Our universal design enables the installation of 60, 72, 96, and 128 cell modules in landscape orientation. All attachments are top mount with one size wrench (1/2"), enabling easy access.

Headquartered in beautiful San Francisco, we welcome you to let us know how we can best serve your needs and look forward to providing you the highest quality, lowest cost solar racking solutions available.

Sincerely,

Elie Rothschild, CEO

Installation Process

The Sollega FastRack 510 Ballasted / Anchored hybrid racking solution is a “Build As You Go” system. FR510 ships with four bolts installed in specific locations on the bucket providing 5dg, 6dg or 10dg tilt. **Do not remove these bolts unless you are changing the tilt/IR spacing on-site.** See spec sheet page

Lifting Racking to the roof and staging

Start installation on the far end of the roof opposite the roof loading (crane, all grade, forklift) location. Pallets are 50”x32”x91”H consisting of two stacks of (45) FR510s and weights (470#). When lifting to the roof ensure the pallets are strapped to the lift. Roof can be staged in single pallet (20-25 kW increments) as per the engineered layout. **Note: Lay the pallets down on the roof to avoid damage from wind. Don’t unpack until ready to install.**

Positioning FR10 – First Two Rows

Mark required fire access pathway setback from roof edge as specified in provided plan set with chalk line or string on the far end of the roof from the roof loading location. The key here is to build out the array (racking, modules, ballast block and mechanical anchors) as you go, keeping the roof open for easy access to the array and minimizing trip obstacles and enabling a quicker installation. If array is facing south the first two rows will be positioned in E-W direction. Note: you can build the system from the front to back or back to front depending on roof loading location. You can also build the system in columns which would be N-S. It is critical to properly align this first row or column as subsequent rows or columns are aligned by spacing of the module against the reference tabs on the FR510.

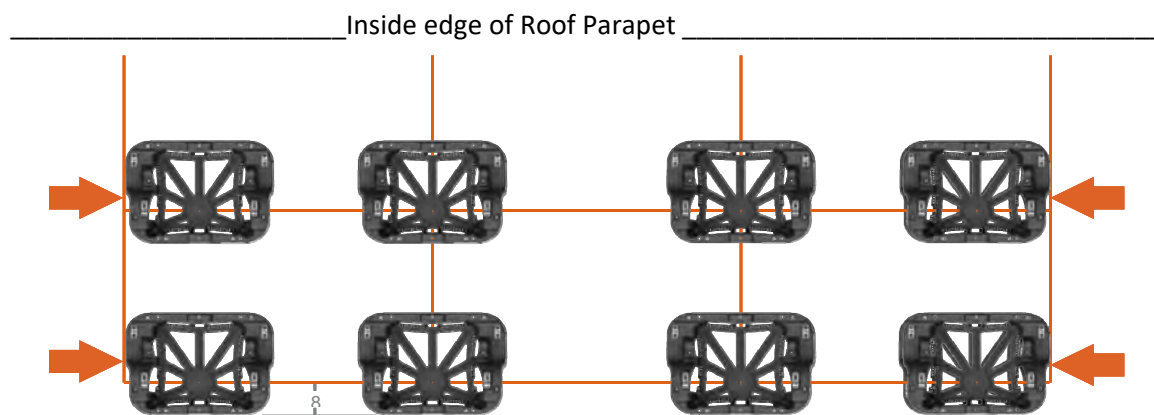

Diagram 1

Note: FR510’s located at the ends of rows are pushed underneath the modules. The module can cantilever past the FR510 based on the clamping zone requirements as per the module manufacturer.

Installation of First Row of Modules

When installing the first two rows of buckets and first row of modules, it is helpful to put one ballast block in the FR510's to keep the racking from moving around. Slide the FR510 so the reference tab is up against the module. See below.

Once the FR510's are positioned (diagram 1) it is now time to install the hardware that holds the modules to the FR510. Locate the aluminum pull clamp (FR-PC) and aluminum end clamp (FR-EC) Note: End clamps vary in size and must match the height of the module frame. They are available in size from 1.18" (30mm) – 1.97" (50mm). Install the pull clamp over the pre-installed bolts in the FR510, push the FR-PC out towards the edge of the FR510 completely. Next install the FR-EC over the bolt on top of the FR-PC. Next loosely install a serrated flange nut (FR-N) on the bolt. With the hardware are in place, the modules can be installed, aligned, and fastened down and tightened. The reference tabs on the FR510 ensure the proper placement of the module on the FR510. There is a reference spacer on the short rail of the module for proper alignment and E-W spacing. Once the modules are aligned, pull the FR-PC back to ensure it is flush up against the lip of the flange on the bottom of the module. The FR-PC and FR-EC are indexed and when tightened form a locked together union.

Note: All serrated flange nuts should be threaded on by hand to avoid galling or seizing of the stainless fasteners, Sollega applies a coating to help alleviate galling. **Do not use an impact driver for installation as this can cause galling and overtightening.** We recommend using a calibrated torque wrench or hand wrench to avoid overtightening.



1. Pull FR-PC flush with bottom flange

2. Install FR-EC & FR-N on Bolt

3. Torque FR-N to 5-10 ft.lbs

Diagram 2

Once the first row is positioned and all fasteners are tightened install the ballast as per Sollega provided ballast schedule. This locks the first row of modules down and enables proper placement of the second row of modules. Repeat process until the array is complete. **Note: All FR510's must have at least one ballast block or mechanical anchor attachment installed.**



FR510-10 North Row

Mechanical Anchor Installation

If mechanical anchors are required, note placement in array and install Sollega supplied anchor assembly consisting of (3x Aluminum L feet/w T-bolt, 8' Aluminum Rail, 2x Carriage bolt (FR-CB), 2x Square Washer (FR-SQW), 2x 3/4" Washers (FR-W2), 1x 3/8" Nylon Lock Nut (FR-NLN), 1x mechanical anchor (FR-MA). Install all connections loose and leave anchor attachment to the roof and flashing to the roof until the array position is confirmed accurate. Install anchor screws (not supplied by Sollega) into the anchor plate as per specified in the project engineering packet. Anchor screws are deck dependent (wood, concrete, metal) and vary in length to accommodate varying thickness of insulation. The mechanical anchor is installed in between two adjoining FR510 as depicted below. See detail page.



Mechanical Anchor Assembly

Slip Sheets Installation

If slip sheets are required, center them under the FR510 during installation. Check with the roofing manufacturer to determine if they are required and if they need to be attached or installed loose. Sollega can provide slip sheets cut to size of the specific roofing material. Request a quote.

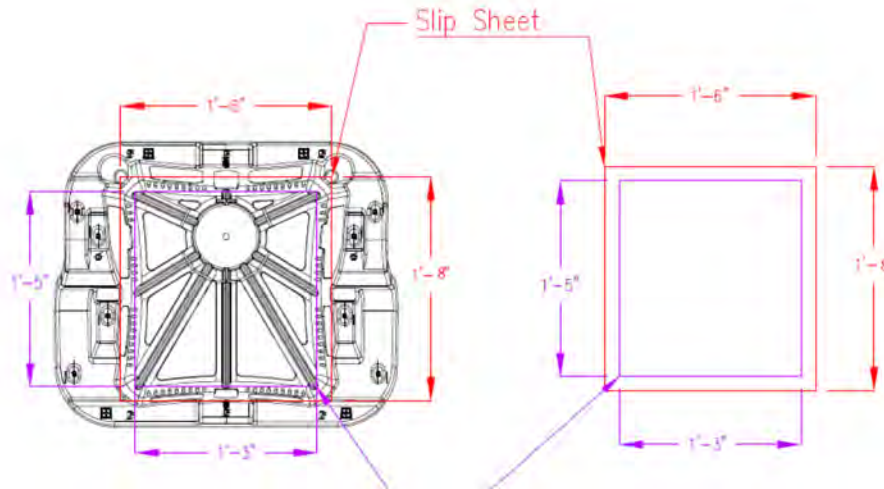

Slide On Bonding Jumper (FR-SBJ) Installation

Sollega's latest racking innovation, the FR-SBJ (Patented) one piece slide-on bonding jumper provides module to module bonding. The easy to install, one piece spring stainless steel part installs without the need of tools. Simply position it between two adjoining modules and slide the end clips onto the adjoining module flanges. The part is designed to work in conjunction with the FR510 ballasted Racking system, but can be used as a standalone solution.



Install FR-SBJ to bottom flange of adjoining modules

Row to Row Bonding Requirements

Attach supplied FR-SGB-4 IlSCO Grounding lug to the module flange of the last module in the row. Install one FR-SGB-4 lug per row and install bare copper (typically #6 or #8) as per wiring single line diagram and connect to ground. Install as per manufacturers guidelines.



FR-SGB-4 Grounding Lug

Optimizer Mounting Detail – Rock-it Clip

ROCK-IT CLIP 2.0 INSTALL

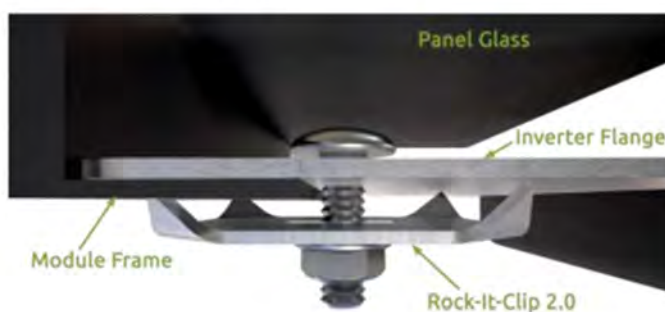

- 1 Locate all parts
 - Locate the Rock-It Clip 2.0, micro-inverter/power optimizer, and the section of the module frame in which you will be mounting the micro-inverter/power optimizer.
- 2 Install the Rock-It Clip 2.0 (See below detail)
 - Slide the Rock-It Clip 2.0 onto the lip of the micro-inverter/power optimizer.
 - Slide the micro-inverter/power optimizer into the opposite lip of the module frame.
 - Tighten the bolt to 150 in-lb to clamp the Rock-It Clip 2.0 to the module frame and the micro-inverter/power optimizer to the Rock-It Clip 2.0.
 - Ensure that the lip on the clip is tight against the frame and that the micro-inverter/power optimizer flange is tight against the clip flange to avoid rotation during tightening.

Wire Management

Sollega provides the FR-W-CLP (UV rated Nylon wire clip with zip tie). This is designed to be installed on the module flange and overhang of the FR510 for N-S wire management. No wires should be exposed to UV.



FR-W-CLP Wire clip

Tools Requirements

Required Tools: ½" Socket Driver, Torque Wrench, cordless drill (slow speed) with clutch setting.

Do not use impact drivers

Required Torque Module Attachment: All connections require 5-10 ft-lb of torque.

Ballast Requirements:

Please follow all current and applicable building codes

For assistance with ballast requirements for a specific project, contact engineering@sollega.com.

Approved roof pavers (ballast blocks or CMUs) dimensions are 16" L x 8" x 4" H with an average weight of 27 to 33 lbs. (Fig 1), unless otherwise noted.

- Pavers should have a minimum net area compressive strength of 3000 psi or must comply with ASTM Designation C1491.



Standard Roof Paver – FR-CMU

The Installer is Solely Responsible For:

- Utilizing all necessary safety equipment as required by applicable rules and regulations.
- Complying with all applicable local or national building codes, including any that may supersede this manual.
- Ensuring that the FR510 and other products provided by Sollega are appropriate for the particular installations and are designed for the installation environment. Roof must be less than 7dg in slope.
- Ensuring that the roof, its rafters, connections, and other structural support members can support the array under live load conditions.
- Ensuring that lag screws used for roof anchoring have adequate pullout strength and shear capacities.
- Maintaining the waterproof integrity of the roof including selection of appropriate flashing.
- Ensuring safe installation of all electrical aspects of the entire system.
- Following the roofing manufacturer's installation procedure and guidelines before beginning the installation.

Disclaimer of Liability:

- SOLLEGA does not assume responsibility and expressly disclaims liability for loss, damage, or expense arising out of, or in any way connected with installation, operation, use, or maintenance by using this manual.
- SOLLEGA assumes no responsibility for any infringement of patents or other rights of third parties, which may result from use of modules. No license is granted by implication or under any patent or patent rights. The information in this manual is believed to be reliable, but does not constitute an expressed and/or implied warranty.
- SOLLEGA reserves the right to make changes to the product, specifications, data sheets and this manual without prior notice.
- This document is not prescriptive regarding safety and does not purport to address all the safety concerns that may arise with its use. Contractors should become familiar with all applicable safety, health, and regulatory requirements before beginning work.

Important Installation Details (continued)

Electrical Safety

Any work done with PV and electrical equipment presents a shock hazard. The FR510 is injection molded from non-conductive polymer and does not require bonding. The FR510 is mechanical solar mounting system and containing no “live” parts. All persons working on installation should coordinate in order to ensure that all personnel are aware of electrical hazards.

Assembly Modifications

Unauthorized field modification of Sollega components or assemblies will void Sollega warranty coverage. Do not cut or drill into the FR510.

General Information

The installation of solar modules requires a great degree of skill and should only be performed by qualified licensed Professionals, including, without limitation, licensed contractors and electricians.

The installer should be familiar with construction standards established by the Occupational Safety and Health Administration (OSHA). They should also plan for safe practice during any installation activity with respect to hazards from tripping, falling, lifting, repetitive stress, and any overhead or electrical hazards.

When working close to building roof edges, consider protection options that reduce worker exposure to fall hazards. Refer to OSHA Sub Chapter 7, Group 1, Article 2.

Project Specific Design Modifications

On-site workers assisting in the installation process may encounter undocumented or unexpected obstacles requiring a modification of the project system design supplied by Sollega. PV arrays are intended to be primarily regular and repeating structures, any modifications to the original design should be noted on working drawings. If the array is disconnected or if the number of rows or length of a row is changed, contact a Sollega engineering for a revised ballast layout.

Care for the Roof

Avoid concentrated loads on the roof that exceed the available reserve. Never drag components into place. Instead, elevate the component, and then move

it manually or with a cart. Locate it and then place it “on spot.” To ensure roofing system warranty continuation, work with roofing contractors to ensure roofing system and array compatibility. Sollega Recommends following roofing manufacturers guidelines when installing. Please consult roofing manufacturers specific requirements. If use of slip sheets is required, Sollega can provide a note for roofing manufacturer specific material slip sheets.

Final inspection

Visually inspect assembled arrays. The suggested process consists of a row-by-row walk-through and then a perimeter walk-around, after mechanical assembly, before electrical completion. Report any distortion in the assembly to Sollega. Array substrate supports should be in full contact with the roof or the ground. Any indication of uneven distribution of weight should be evaluated and corrected before continuing with electrical finishing.



FastRack510™

The simple solar racking solution for flat roof or ground mount PV installations.

- 5°, 6°, 10° mounting solution
- Simple, modular, one piece design
- Universal design compatible with all framed modules
- Fully ballasted, heat welded, anchored and hybrid options
- Roof friendly with round edges and low point loads
- One size bolt with all top down connections
- Injection molded UV rated Nylon6
- PE stamp engineering and ballast layout services available
- UL 2703 Class "A" Type 1, 2, 3 Modules
- UL 467 Integrated grounding
- 100% Recyclable
- Made in the U.S.A.

Easy to install:

1 Position FastRacks



2 Add Ballast and Clamps



3 Attach Modules





Sollega FastRack String Inverter Mount

- Invert in the array
- 20° Tilt
- Ballast & mechanical attachment options
- Flexible Strut configuration
- Mount most string inverters, combiner boxes and disconnects
- Quick to install



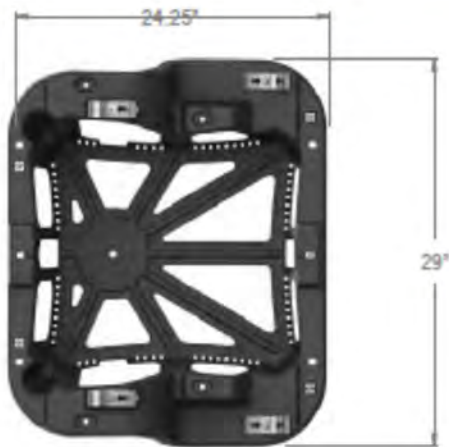

FastRack 510 (10° Shown)

Tit Angle	5°	6°	10°
Row Spacing	10" (254 mm)	8" (203mm)	13" (330 mm)
Leading Edge	8" (203 mm)	8" (203 mm)	5.3" (135 mm)
Compatible Modules	All framed modules 31" - 44" in width (787 mm and 1117 mm)		
Weight	4.5 lbs. (2 kg)		
Ballast Requirements	4" x 8" x 16" Roof Paver (31.5 lbs each) based on ASTM Designation C1491 - 01a.		
Material	Injection molded UV rated Nylon6		
Module Orientation	Landscape		
Wind Load Criteria	Meets ASCE 7-10 up to 165 mph		
UL Certification	UL 1703: Class 'A' Type 1,2,3 Modules, UL2703		
Warranty	25 Year Limited Warranty		
Dimensions	(LxWxH) 24.25 x 29 x 14"		
	616 x 737 x 356mm		
Disassembly	Simple disassembly and 100% recyclable content		
Patent	Utility Patent #9,831,817 Design Patent #D800,055		

Bolt Location

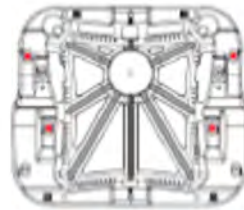

5° (10" Inter-row)

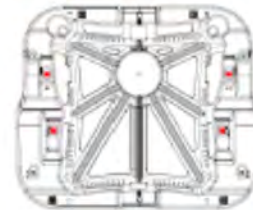

6° (8" Inter-row)

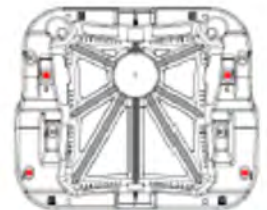

10° (13" Inter-row)



Mechanical Anchor styles and cross section details

U-2000
Heatweld
only
Single
Ply Roof

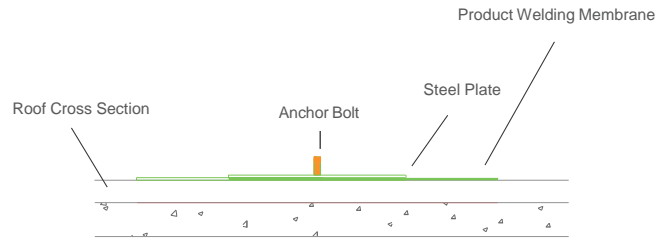

U-2400
Mechanical
fastened
Single Ply
Roof

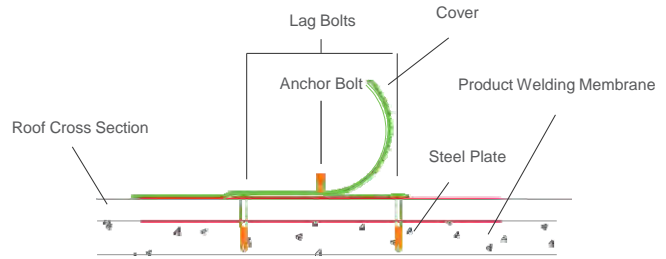

U-2600
Mechanical
fastened
built up Roof

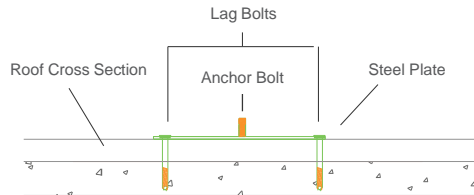

Mechanical Anchor Installation

The FR510 center mounting hole is utilized for attachment of aluminum L foot/Rail/Anchor.

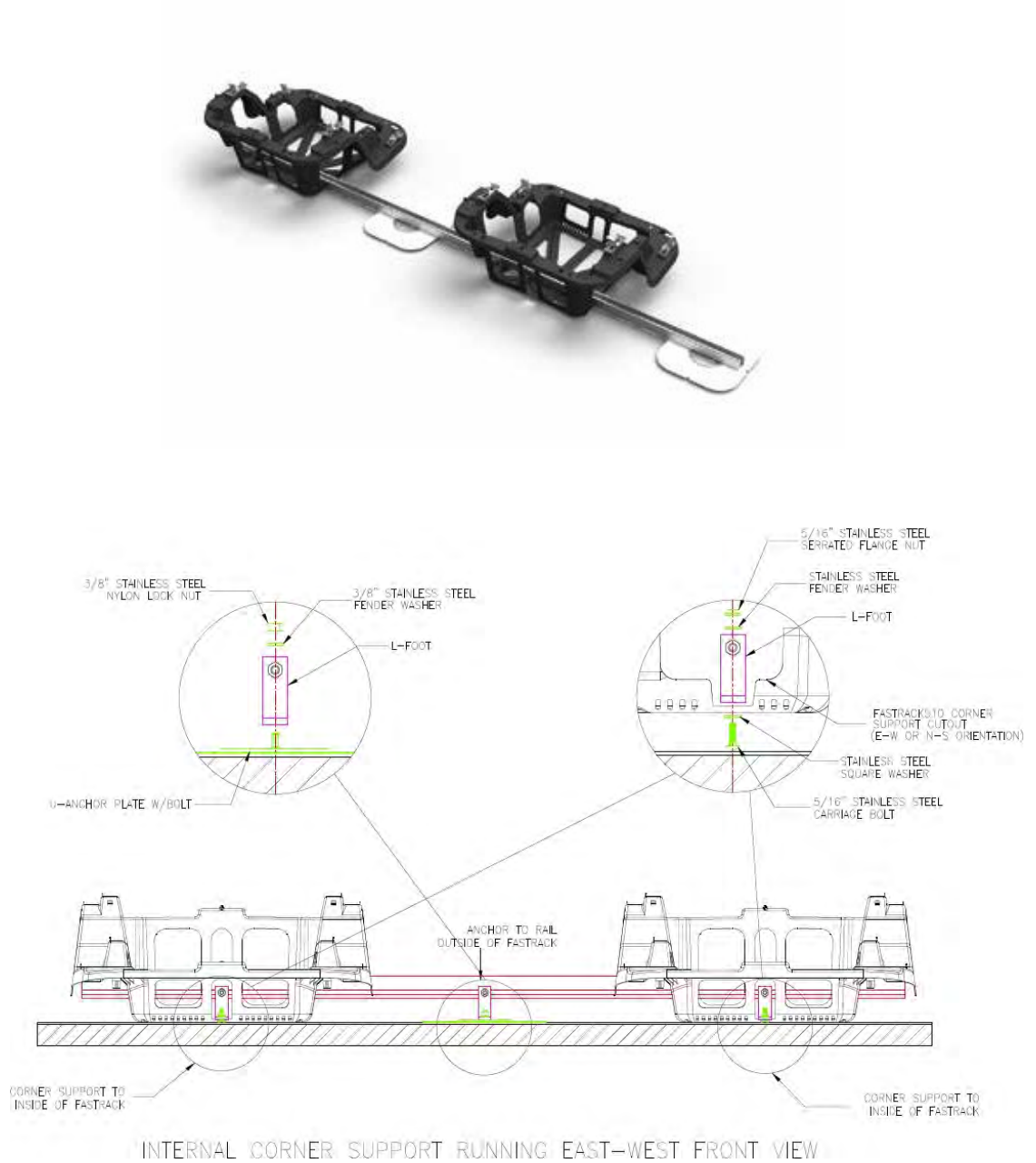

Illustration 1a - List of approved modules when bonding modules with AK Stamp	
Manufacturer	Model
GCL	M6/72H

Illustration 1b - List of approved modules when bonding modules with Bonding Jumper	
Manufacturer	Model
GCL	M6/72H
Heliene	144M M6 Monofacial 450W-460W
LG	LG335N1C-A5 LG405N2T-L5
SunPower	SPR-A425-G-AC, SPR-A420-G-AC, SPR-A415-G-AC, SPR-A410-G-AC, SPR-A400-G-AC, SPR-A390-G-AC, SPR-A400-BLK-G-AC and SPR-A390-BLK-G-AC
Q-Cell	G4.4L Q.PEAK DUO XL-G10.3/BFG/BGT470-485, Q.PEAK DUO XL-G10/G10.2/G10.3470-485 Q.PEAK DUO XL-GG9.3/BFG/BGT440 - 460, Q.PEAK DUO XL-G9/G9.2/G9.3440 - 460 Q.PEAK DUO L-G8.3/BFG/BGT405 - 430, Q.PEAK DUO L-G8.3/BFF405 - 430 Q.PEAK DUO L-G8.3 405 - 430, Q.PEAK DUO L-G8.2 405 - 430 Q.PEAK DUO L-G8.1 405 - 430, Q.PEAK DUO L-G8 405 - 430 Q.PEAK DUO L-G7.7385-405, Q.PEAK DUO L-G7.4385-405 Q.PEAK DUO L-G7.3 385-405, Q.PEAK DUO L-G7.2 385-405 Q.PEAK DUO L-G7.1 385-405, Q.PEAK DUO L-G7 385-405 Q.PEAK DUO L-G6.3 405 - 430, Q.PEAK DUO L-G6.2 405 - 430 Q.PEAK DUO L-G6 405 - 430, Q.PEAK DUO L-G5.3 380-405 Q.PEAK DUO L-G5.2 380-405, Q.PEAK DUO L-G5380-405 Q.PLUS DUO L-G5.3 360-380, Q.PLUS DUO L-G5.2 360-380 Q.PLUS DUO L-G5 360-380, Q.PEAK L G4.5 365-385 Q.PEAK L G4.2 365-385, Q.PLUS L G4.2 340-355
REC	Alpha 72 Series/RECxxxAA 72 where xxx is 430-450W
Trina	TSM-DE15H, TSM-DE15M, TSM-DD06M.05, TSM-DE06X.05(II), TSM-DEG15HC.20(II), TSM-DEG15MC.20(II), TSM-DE15V(II), TSM-DEG15VC.20(II), TSM-DE09.05 (II), TSM-DE19, TSM-DEG19C.20

Sollega FastRack 510 25-Year Warranty

SOLLEGA Inc.™ is dedicated to providing excellent customer support and service and will continually evolve our warranty to enhance our dealers' and customers' experiences with SOLLEGA. The following policies and procedures are subject to change as our process evolves.

SOLLEGA Inc. warrants that its FastRack™ Photo-voltaic (PV) Module Mounting System, when sold and delivered pursuant to a SOLLEGA Sales Order, will be new, will conform to the specifications in the applicable SOLLEGA Sales Order, and will be free from defects in material and/or workmanship for a period of Twenty Five (25) years from the date of shipment. Except for the foregoing limited warranties, SOLLEGA makes no other warranties express or implied for its SOLLEGA FastRack.

This Warranty does not apply to damage incurred during shipment and does not apply to damage that is the result of improper handling. This Warranty will be void if during the warranty period, the SOLLEGA FastRack has been improperly or incorrectly installed, used, or maintained, or has been operated under abnormal conditions or contrary to applicable specifications.

This Warranty is granted to the original SOLLEGA FastRack owner only and is only applicable to the original installation of the SOLLEGA FastRack. This Warranty does not apply to damage to the SOLLEGA FastRack that is the result of weather conditions that exceed local building code limits that were applicable at the time that the SOLLEGA FastRack was originally installed.

It is recognized and agreed that the foregoing limited warranties are in lieu of all other warranties, whether express or implied, and that SOLLEGA Inc. does not make any warranty of merchantability or any warranty of fitness for a particular purpose.

In the event the SOLLEGA Inc. FastRack fails to satisfy the foregoing limited warranties, then SOLLEGA will repair or replace, at its option and cost, the defective product. The foregoing remedy shall be in lieu of all others that the SOLLEGA Purchaser may have, and the Purchaser waives all other remedies.

To obtain warranty service, the Purchaser should contact SOLLEGA Inc. by telephone or email, and SOLLEGA will establish a claim file and initiate action to repair or replace the defective product. SOLLEGA will work with the Purchaser to determine the extent of the problem and may elect to perform a site inspection.

SOLLEGA Inc. will not assume expense or liability for correction of a defective SOLLEGA FastRack by the Purchaser or by third parties without SOLLEGA's prior written authorization. In the event of the authorized correction of a defective SOLLEGA FastRack, the warranty period will be extended by the length of time during which the defective equipment was in the process of being repaired or replaced. Unauthorized field modification to SOLLEGA's final layout will affect warranty coverage. If any changes are made that significantly affect the structural integrity of the system, customer must provide written drawings for SOLLEGA's review, comment and approval prior to attempting any field modifications. Modifications may include but are not limited to changes in location of FastRacks, modules, windscreens, roof anchors, roof pavers or any other racking system components. SOLLEGA Inc.'s total liability hereunder for the repair or replacement of a SOLLEGA FastRack, or any defective components thereof, shall not exceed the original purchase price of the system. In no event will SOLLEGA Inc. be liable for or responsible to the Purchaser, or to any other party, for any consequential, incidental, or special, loss, cost, damage, or expense arising from the curtailment or interruption of photo-voltaic (PV) system operation or from the curtailment or interruption of any operations, processes, or equipment connected to the PV system.

This warranty grants the purchaser specific legal rights that may vary according to the state in which the Sollega FastRack is installed. In some states, sellers cannot limit the rights of the purchaser, so you may have access to legal remedies in addition to or greater than those specified here.

This warranty does not cover failures resulting from freeze damage, fire, flood, lightning, hurricane, tornado, hailstorm, windstorm, earthquake, or other acts of god, vandalism, explosions, exposure to harmful materials or fluids, or unauthorized alterations or repairs or any other cause beyond the control of SOLLEGA Inc.

Contact Us

Western USA: 415.648.1299
info@Sollega.com | www.Sollega.com

Sollega USA

Tel: (415) 648-1299

